

Coordinates

記号	X	Y	R
C	0	0	—
DH11	12739	5435	—
DH12	-12739	-5435	—
a1	12065	10124	2100
a2	-10124	12065	2100
a3	-12065	-10124	2100
a4	10124	-12065	2100

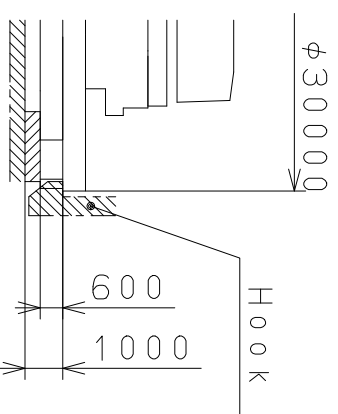
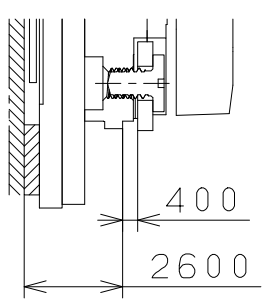

Mark	Date	Description	Appro.	Checked	Drawn	Name:
Alterations			Approved			N. Suzuki
Material						Frame for Case
Heat Treatment						Drawing No.: 9110C000
Hardness						
Plating						

Quantity	Unit	Cal. NO.:
1	1/1000 mm	9110

Scale	Parts No.:
5 : 1	

Material	General Tolerances

**MIYOTA**  
CITIZEN WATCH CO., LTD. TOKYO, JAPAN

confidential papers 2012/12/05 (09:10:27)

This drawing is provisional and subject to our reconfirmation and/or revision without notice.

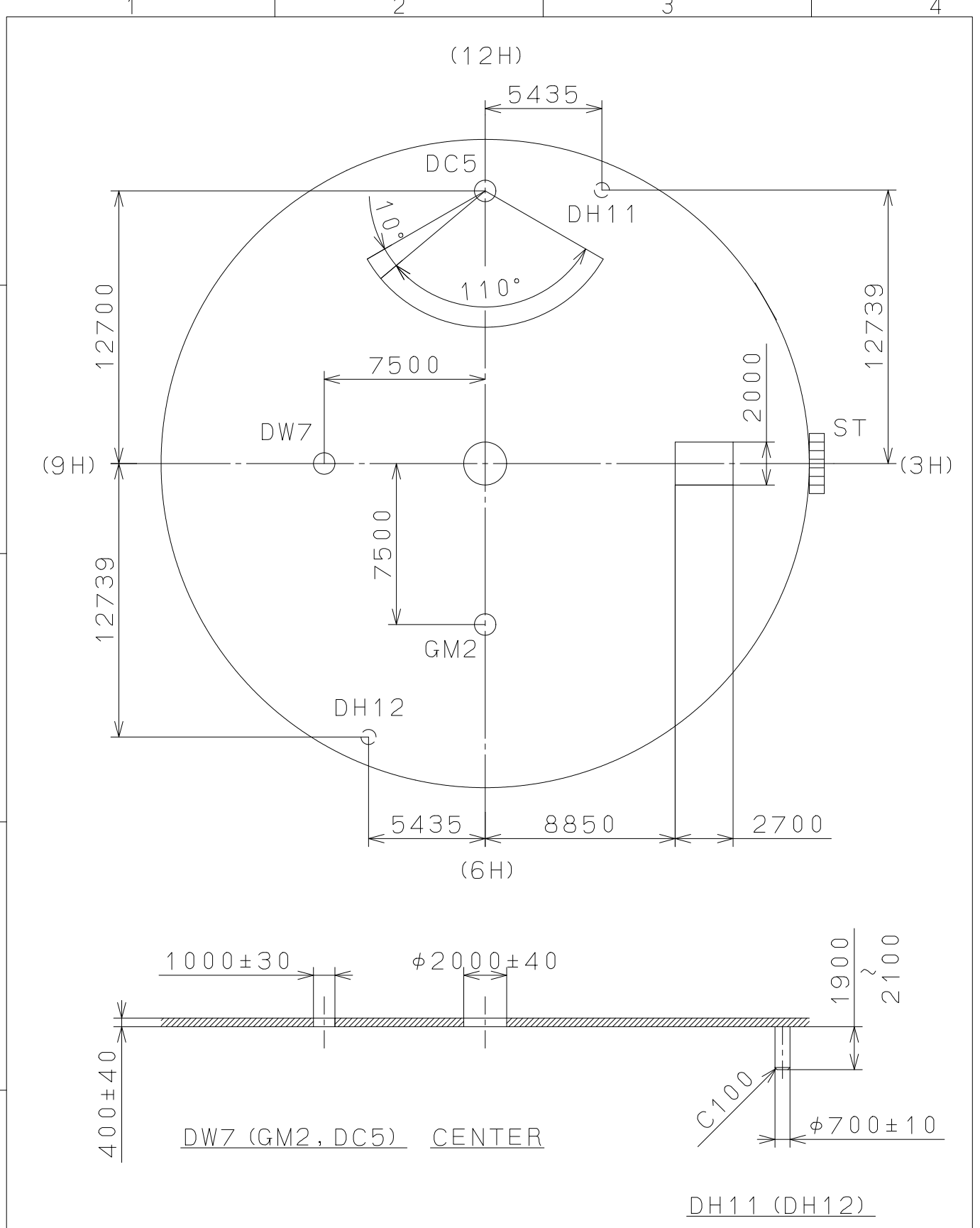

△			Quantity		Cal.NO.:
△			Unit	1/1000 <sub>mm</sub>	9110-20A
△			Scale	4:1	Parts No.:
△			Date		
△			Drawn		
Mark	Date	Description	Appr.	Checked	Name:
		Alterations	Approved	N. Suzuki	Indications for Dial
Material					Drawing No.: 9110D000
Heat Treatment			General Tolerances	<b>MIYOTA</b> CITIZEN WATCH CO., LTD. TOKYO, JAPAN	
Hardness			Dimensions		
Plating			Angles		

2009/03/19 (15:03:29)

This drawing is provisional and subject to our reconfirmation and/or revision without notice.

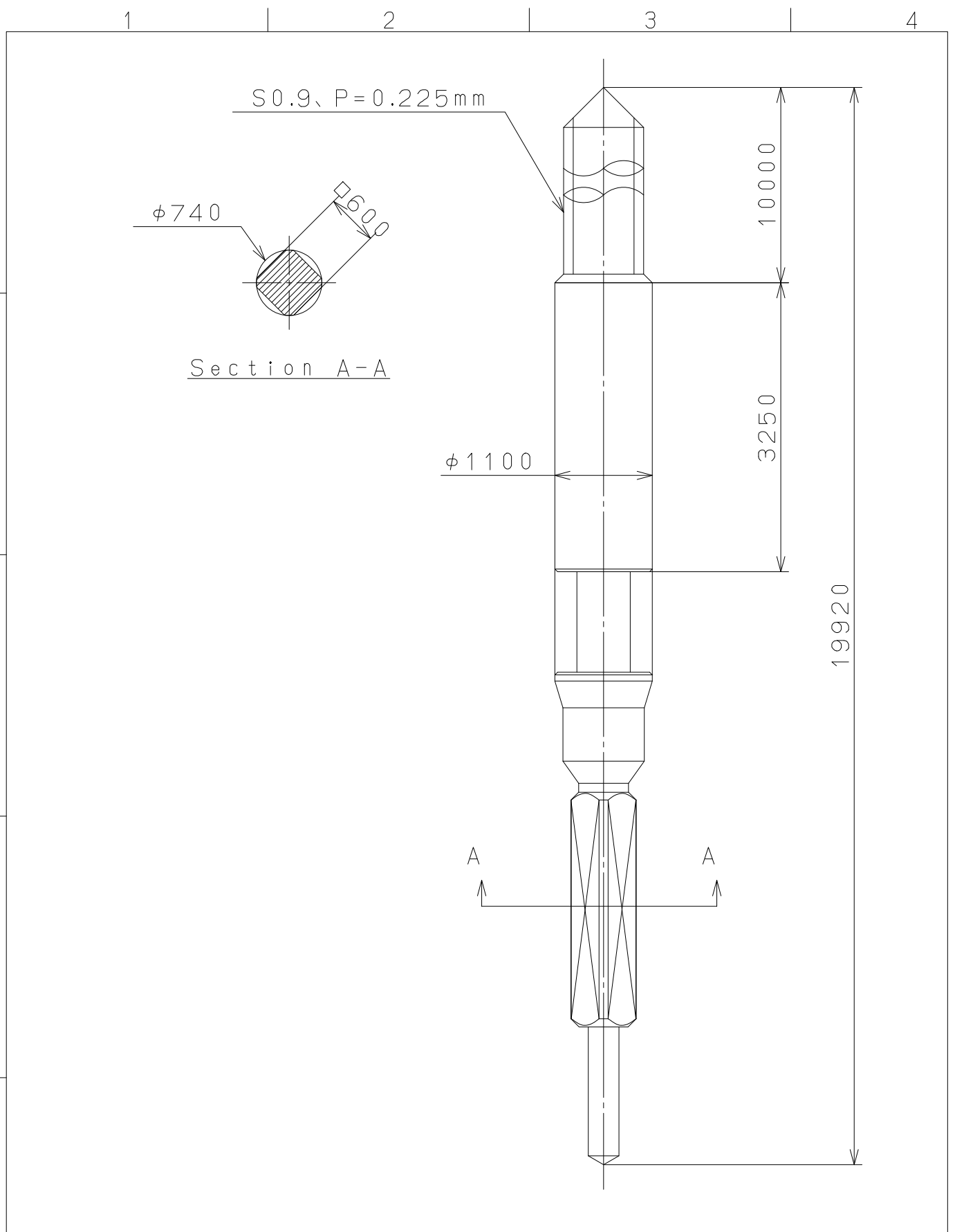

△5			Quantity		Cal.NO.:
△4			Unit	1/1000mm	
△3			Scale	17:1	Parts No.:
△2			Date		065-A05
△1			Drawn		
Mark	Date	Description	Appr.	Checked	Name:
		Alterations	Approved	N. Suzuki	SETTING STEM
Material					Drawing No.: A050S000
Heat Treatment			General Tolerances	<b>MIYOTA</b> CITIZEN WATCH CO., LTD. TOKYO, JAPAN	
Hardness			Dimensions		
Plating			Angles		